

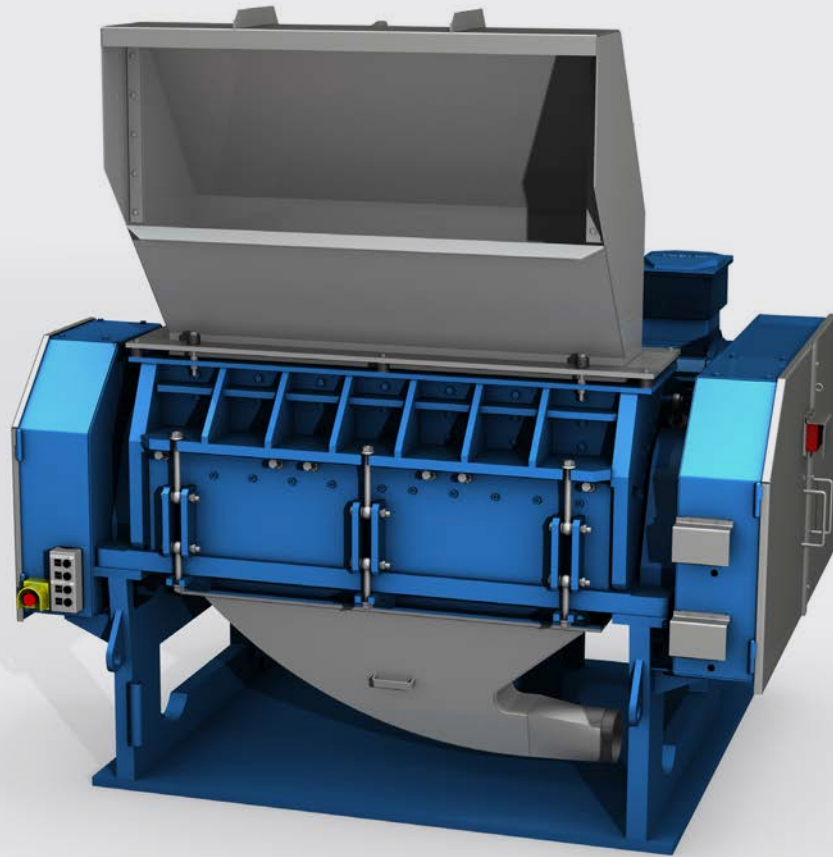

# Eldan Fine Granulator



The Eldan Fine Granulator is a high speed, single shaft granulator for the final granulation step.

The Fine Granulator is specially designed for processing material like:

- Tyres
- Cables
- Aluminium scrap (all types)
- Plastics
- Etc



*Fine Granulator as a part of a tyre recycling system. Feeding via a Silo (V4) to ensures optimum utilization of the capacity.*

## Features

- Adjustable knife clearance optimizing the cutting function
- The knives can be reground multiple times on a “flat-bed” grinder ensuring long life and low operation costs
- The design of the machine ensures quick and easy change of knives
- Hydraulically operated inlet hopper provides easy access to the cutting chamber for maintenance.
- Exchangeable wear parts give you a virtually indestructible machine
- Screens with different hole sizes available to ensure a more flexible production

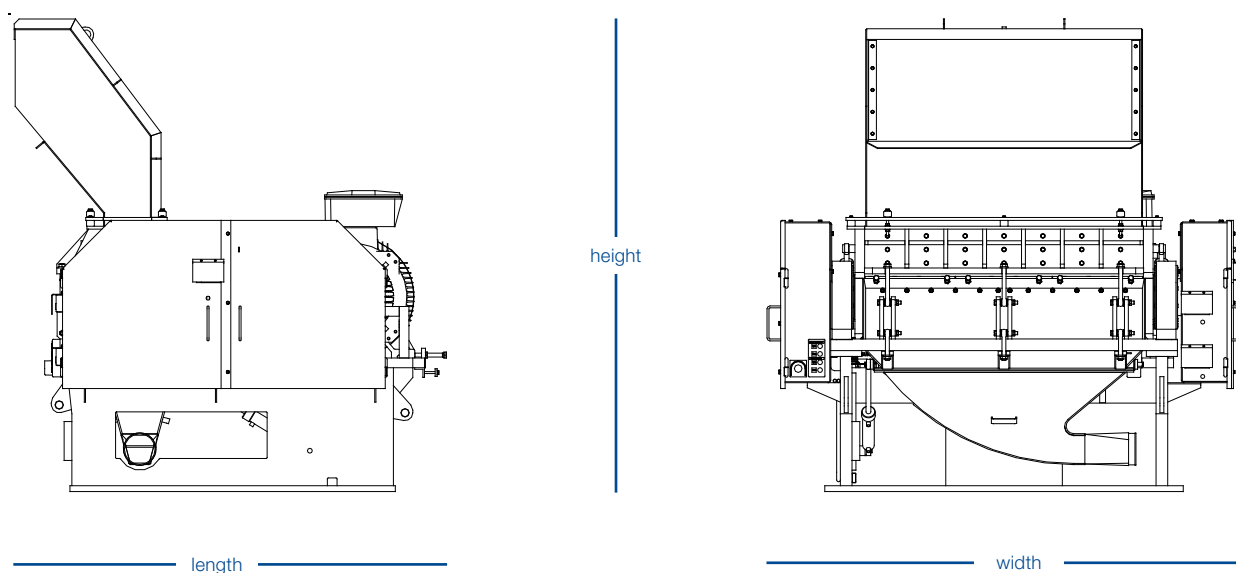

Specifications	FG476	FG952	FG1504
Rotor	475 mm / 475 rpm	950 mm / 475 rpm	1425 mm / 430 rpm
Knives	6 flying/2 static	12 flying/4 static	18 flying/6 static
Capacity *	Up to 2000 kg/hour	Up to 3500 kg/hour	Up to 4500 kg/hour
Motor	45 kW/1480 rpm	75 kW/1480 rpm	110 kW/1480 rpm
Weight	Approx. 3400 kg	Approx. 4400 kg	Approx. 7750 kg
Dimensions	1900 x 1250 x 2800 mm	1940 x 1960 x 2800 mm	2100 x 2500 x 2900 mm

\* Depending on type of input material, method of feeding and screen size  
 Standard voltage: 3 ph, 400, 50 Hz – for other voltages please contact our sales department