

# ELDAN Super Chopper II - SC1412-II FD/SD

Up to 24000 kg/h

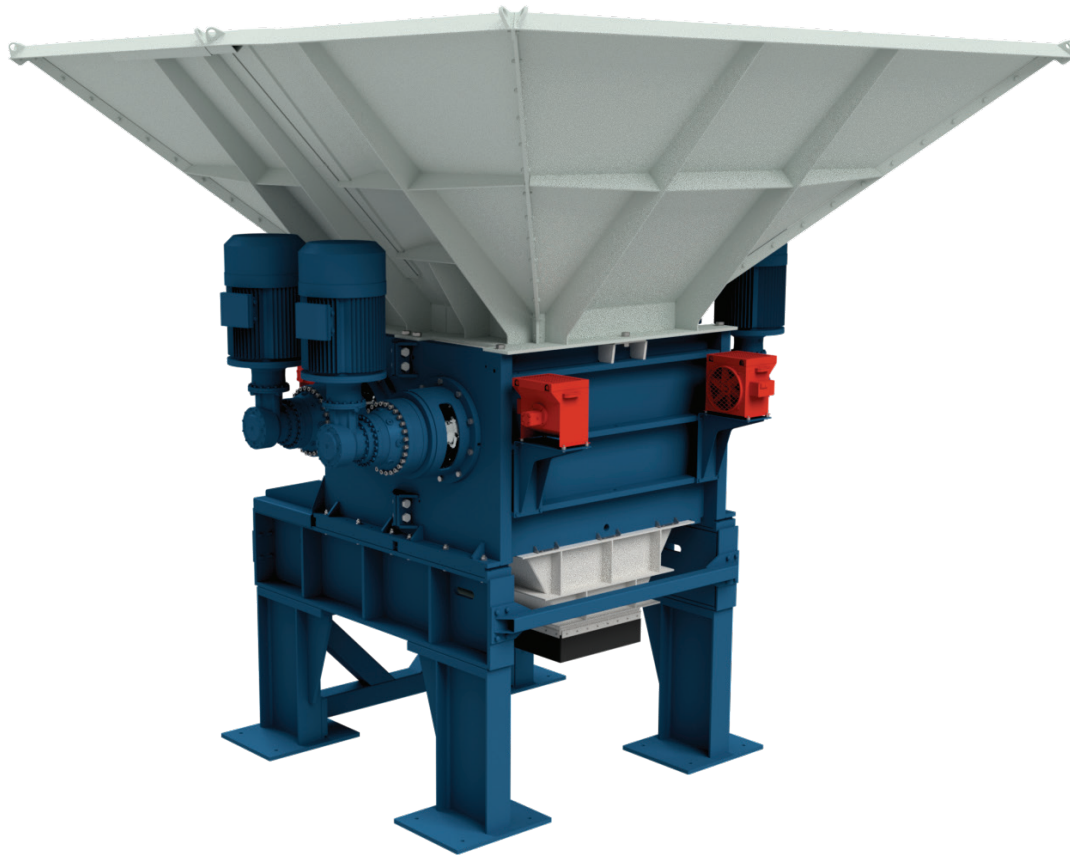

## SUPER CHOPPER II - SC1412-II frequency drive

The ELDAN Super Choppers are heavy duty pre-choppers designed as first step in any recycling process. The Super Choppers can be used for pre-chopping of most materials like tyres (without prior debanding), all types of aluminium scrap, cables, electronic and electrical waste (i.e. WEEE), refrigerators, municipal solid waste (i.e. MSW), wind turbine wings (cut-off), plastics and industrial waste.

- Low speed, high torque enabling processing of tough material
- Powered directly by planetary gears and frequency converters enabling automatic reverse for overload protection to minimize knife damages
- Starts up when fully loaded with material, thus reducing downtime after shutdown
- Adjustable knife clearance optimizes the cutting function
- The knives can be reground multiple times on a "flat-bed" grinder ensuring long life and low operation costs
- The machine is designed for quick and easy change of knives
- Unique rotors manufactured and designed for minimum wear
- Hydraulic operated opening for easy access to the rotor
- The rotors can be individually controlled
- Rough screening bars ensure reduced output size with the option of reducing output down to <math><100\text{ mm}</math> / 4"
- Frequency drive reduces power consumption by up to 50%



*Watch the  
Super Chopper  
in action!*

# Super Chopper II - SC1412-II FD/SD

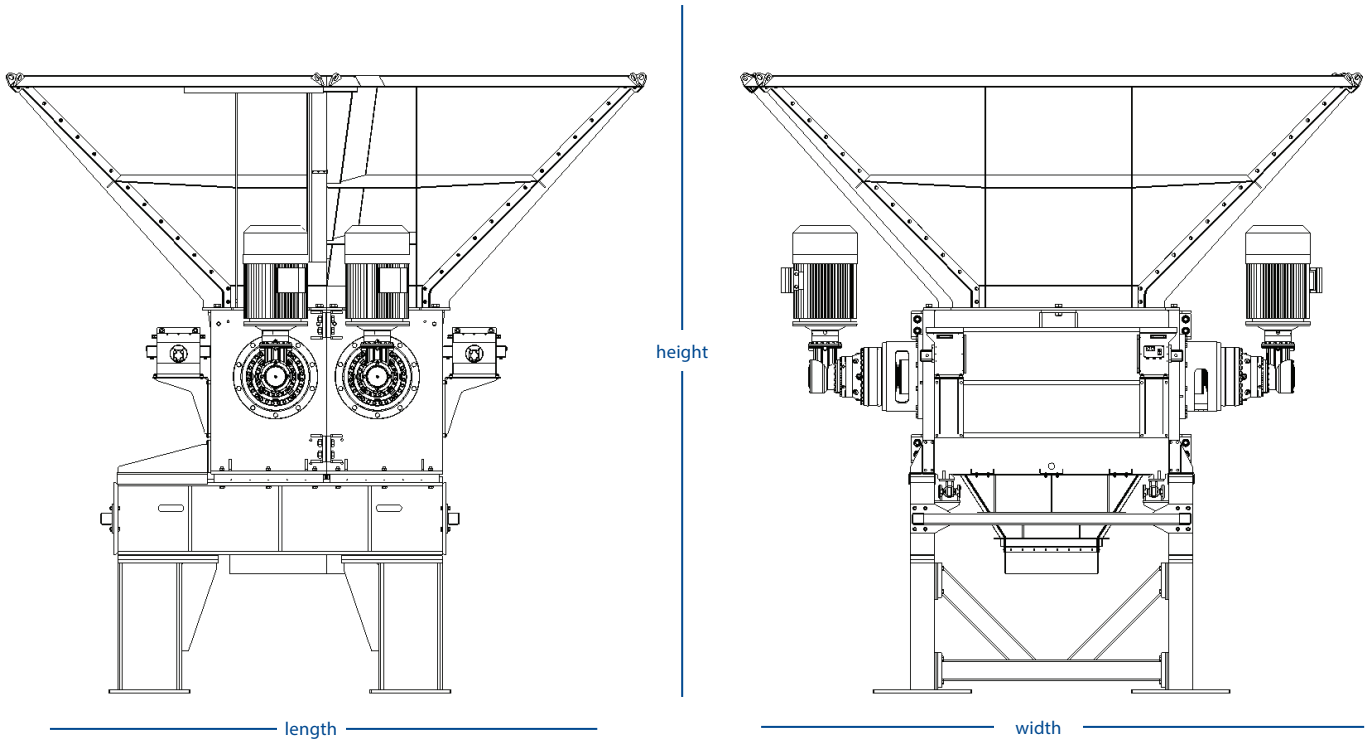

TECHNICAL SPECIFICATIONS	SC1412-II FD/SD 150	SC1412-II FD/SD 300	Units (EN / US)
Electrical motor	2 x 75 / 2 x 100	4 x 75 / 4 x 100	kW / hp
Transmission	2 x planetary gear	4 x planetary gear	pcs
FD-vesion	-	4	frequency converter
SD-vesion	2	4	frequency converter
Rotor length	1400 / 55 each	1400 / 55 each	mm / in
Rotor speed	5-30	5-30	rpm
Knives - flying	24	24	pcs
Knives - static	14	14	pcs
Capacity *	Up to 12000 / 26400	Up to 24000 / 53000	kg/lbs per production hour
Weight (approx.)	26000 / 57000	28000 / 62000	kg / lbs
Length	4600 / 181	4600 / 181	mm / in
Width	5100 / 200	5100 / 200	mm / in
Height	4900 / 192	4900 / 192	mm / in

Standard voltage: 3 ph, 400 V, 50 Hz - for other voltages please contact our sales department  
 \* Depending on type of input material and method of feeding

