

# ELDAN Super Chopper - SC1412/SC1406 FD/SD

Up to 12000 kg/h

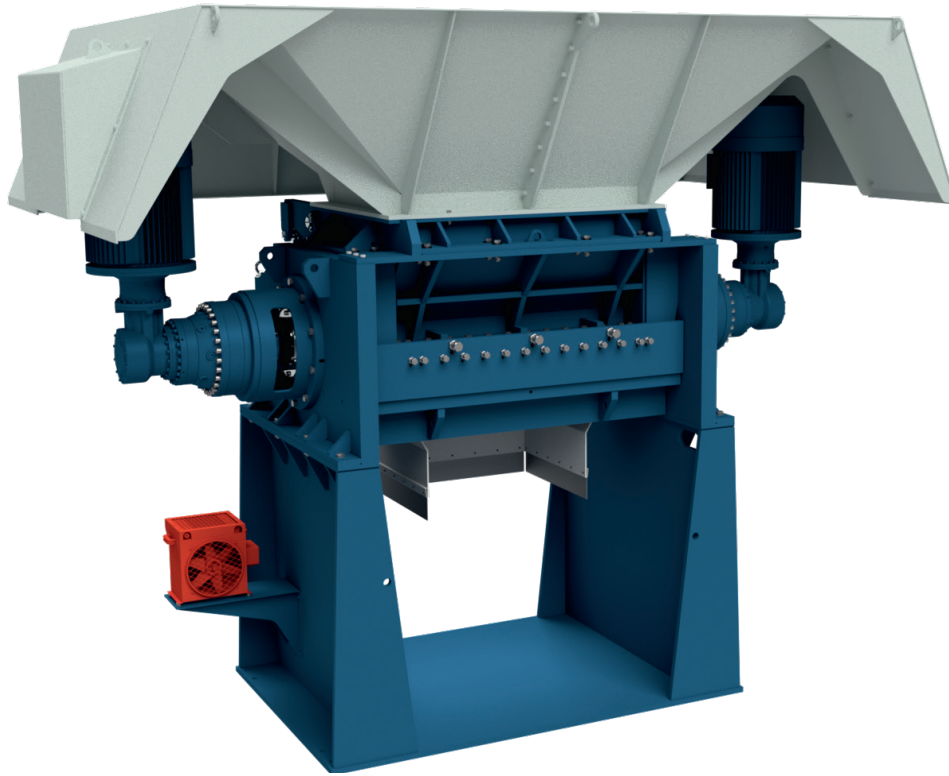

## SUPER CHOPPER SC1412/SC1406 - Frequency Drive / Smart Drive

The ELDAN Super Choppers are heavy duty pre-choppers designed as first step in any recycling process. The Super Choppers can be used for pre-chopping of most materials like tyres (without prior debanding), all types of aluminium scrap, cables, electronic and electrical waste (i.e. WEEE), refrigerators, municipal solid waste (i.e. MSW), wind turbine wings (cut-off), plastics, and industrial waste.

- Low speed, high torque enabling processing of tough material
- Powered directly by planetary gears and frequency converters enabling automatic reverse for overload protection to minimize knife damages
- Starts up when fully loaded with material, thus reducing downtime after shutdown
- Adjustable knife clearance optimizes the cutting function
- The knives can be reground multiple times on a "flat-bed" grinder ensuring long life and low operation costs
- The machine is designed for quick and easy change of knives
- Unique rotor manufactured and designed for minimum wear
- Optional hydraulic operated upper part for easy access to the rotor
- Rough screening bars ensure reduced output size with the option of reducing output down to <math><100\text{ mm}</math> / 4"
- Frequency drive reduces power consumption by up to 50%



Watch the  
Super Chopper  
in action!

# Super Choppers - SC1412/SC1406 FD/SD

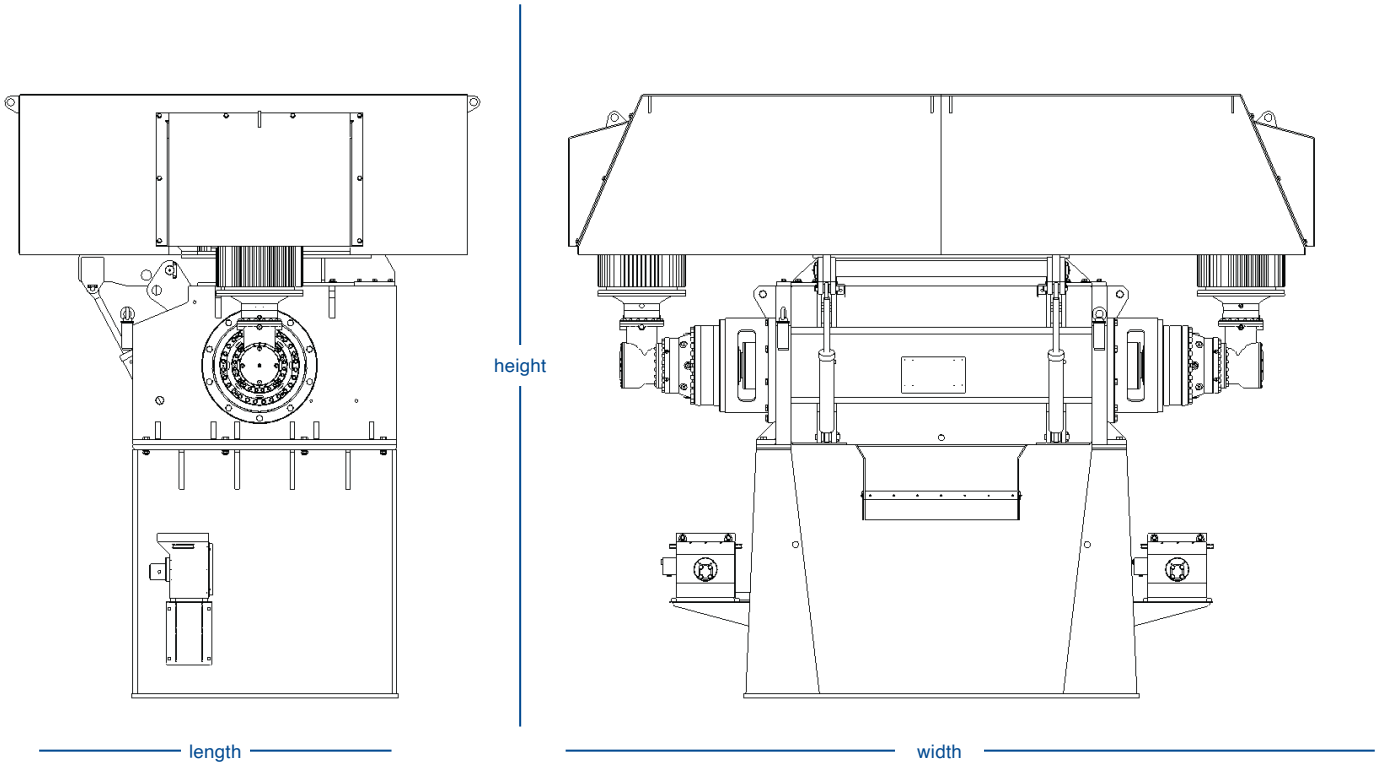

TECHNICAL SPECIFICATIONS	SC1412 FD/SD75	SC1412 FD/SD150	SC1406 FD/SD150	Units (EN / US)
Electrical motor	1 x 75 / 1 x 100	2 x 75 / 2 x 100	2 x 75 / 2 x 100	kW / hp
Transmission	1 x planetary gear	2 x planetary gear	2 x planetary gear	pcs
FD-version	-	1	1	frequency converter
SD-version	1	2	2	frequency converter
Rotor length	1400 / 55	1400 / 55	1400 / 55	mm / in
Rotor speed	5-30	5-30	5-30	rpm
Knives - flying	12	12	6	pcs
Knives - static	7	7	7	pcs
Capacity *	Up to 6000 / 13250	Up to 12000 / 26500	Up to 12000 / 26500	kg/lbs per production hour
Weight (approx.)	15000 / 33100	15000 / 33100	15000 / 33100	kg / lbs
Length	1850 / 73	1850 / 73	1850 / 73	mm / in
Width	4850 / 191	4850 / 191	4850 / 191	mm / in
Height	3750 / 148	3750 / 148	3750 / 148	mm / in

Standard voltage: 3 ph, 400 V, 50 Hz - for other voltages please contact our sales department

\* Depending on type of input material and method of feeding

