

ELDAN Multi Purpose Rasper 240HD for ASCR cable

Up to 16 000 kg/h

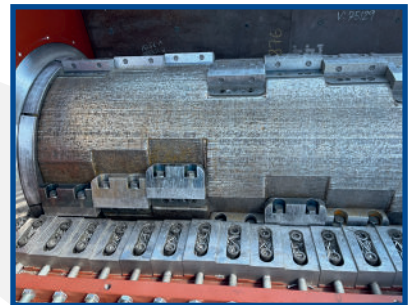

MULTI PURPOSE RASPER 240HD (Heavy Duty)

The ELDAN Multi Purpose Rasper 240HD is a heavy duty rasper modified for recycling of tough material, e.g. ASCR cables

- High inertia from the flywheel ensures an even load on the machine, thus yielding a higher cutting power
- Friction clutches protect the machine from material overload
- Belt driv ensures a simple transmission
- Adjustable knife clearance optimizes the cutting function
- The knives can be reground multiple times on a “flat-bed” grinder ensuring long life and low operation costs
- Designed for quick and easy change of knives and screens
- The rotor is manufactured and designed for minimum wear
- Screens with different hole sizes are available for flexible production
- Exchangeable wear parts give you a virtually indestructible machine



Watch the
MPR 240HD
in action!

Multi Purpose Rasper 240HD for ASCR cable

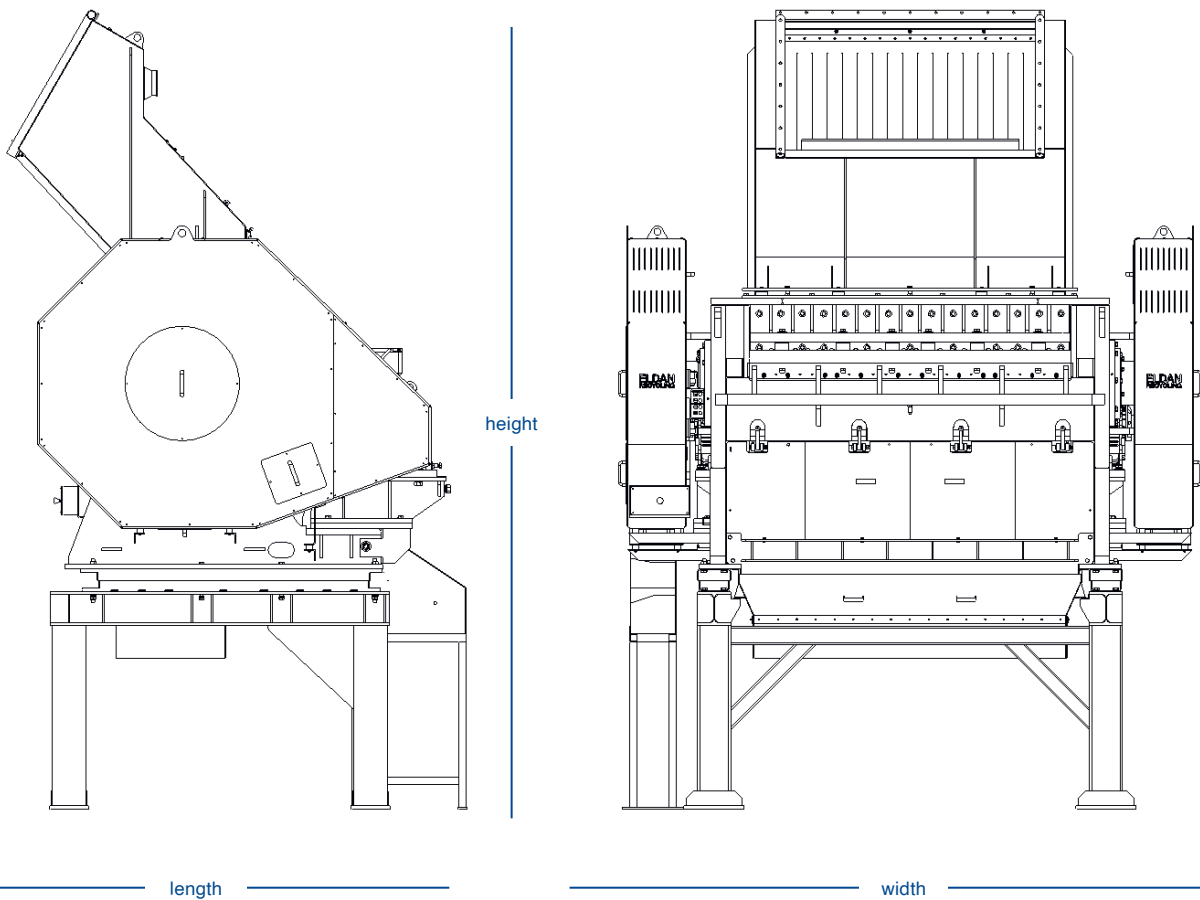

OPTIONAL FEATURE

The Multi Purpose Rasper HD can be delivered with frequency converter for added benefits:

- Starts up when fully loaded with material, reducing downtime after shutdown
- Enables adjustable rotor speed
- Reduced power supply costs
- Reduced power consumption by up to 40%

Technical Specifications	MPR240HD	Units (EN)
Motor		kW / hp
Rotor length	2400 / 95	mm / in
Rotor speed	125	rpm
Knives - flying	60	pcs
Knives - static	31	pcs
Capacity*	6000 / 13000	kg / lbs
Belt driven	Twin	
Weight	36000 / 79000	kg / lbs
Length	2800 / 110	mm / in
Width	4900 / 193	mm / in
Height	5410 / 213	mm / in

* Depending on type of input material, method of feeding and screen size
Standard voltage: 3 ph, 400 V, 50 Hz – for other voltages please contact our sales department

