

# The best of ALUMINIUM RECYCLING

- Tailored to suit your requirements and facility.
- High performance.
- Homogenous output fraction.
- Low processing costs.



## Aluminium recycling plants and machines

To achieve the required type of end-product different standard recycling plants are available. These standard plants are also the starting point when plants are tailored to suit specific customer requirements. Using the modular approach, a large number of combinations can be supplied to produce shreds, chips and granules.

Typical input material will be: soft and hard aluminium material, clean as well as contaminated material, sheets, blanks, profiles, litho, castings, turnings, foils, UBCs, "old rolled aluminium" and many others.

## Proven technology

Eldan equipment is designed to meet market requirements, thus the individual machines can easily be adjusted to other fraction sizes, merely by changing the screen size in the machines.

1. **Super Chopper.** A powerful, low-speed, single or dual shaft pre-chopper including automatic reverse for overload protection. Fraction size approx. 100-300 mm shreds.
2. **Overband Magnet.** Removes ferrous material from the aluminium.
3. **Tumble Back Feeder.** Ensures a continuous flow into the Multi Purpose Rasper thus ensuring an optimum load/ utilization of the Multi Purpose Rasper.
4. **Multi Purpose Rasper.** An effective, medium-speed, dual drive Rasper designed for aluminium recycling. It ensures individual size reduction down to approx. 20-80 mm.
5. **Overband Magnet.** Removes ferrous material from the aluminium.
6. **Eddy Current Separator.** The Eddy Current Separator ensures the separation of organic material from the aluminium.
7. **Heavy Granulator.** A high-speed, single shaft Heavy Granulator for the first granulation stage (remaining Fe-material is liberated). Fraction sizes typically between 8-13 mm granules.
8. **Overband Magnet.** Removes the very last ferrous material from the aluminium ensuring an almost 100 % clean aluminium fraction.
9. **Fine Granulator.** A high-speed, single shaft Fine Granulator for the second and final granulation stage. Fraction sizes typically between 4-8 mm granules.
10. **Separation Table.** This machine ensures final size distribution.

## Benefits

- Extensive experience since 1956.
- High performance.
- Low processing costs.
- Low power consumption.
- Low maintenance costs.
- ELDAN plants are tailored to suit your requirements and facilities.
- The modular concept behind the ELDAN plants enables you to adapt your production output fraction to specific customer demands.
- Homogeneous output.

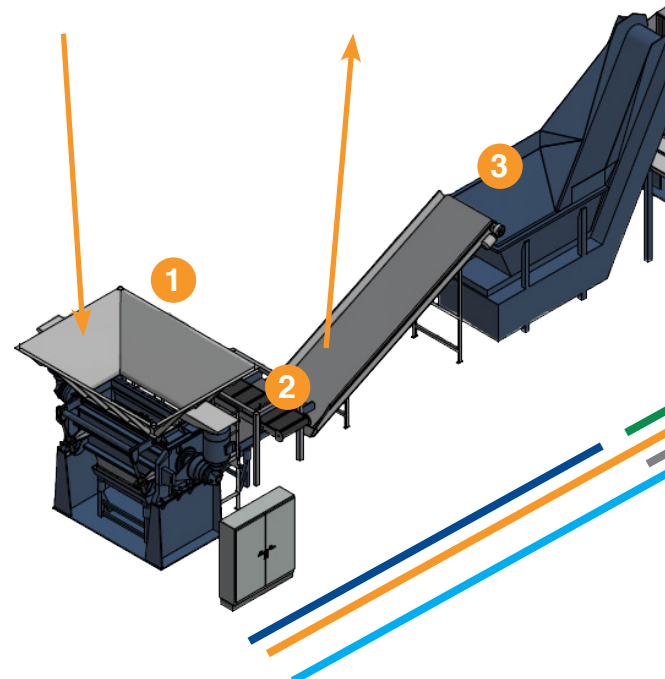

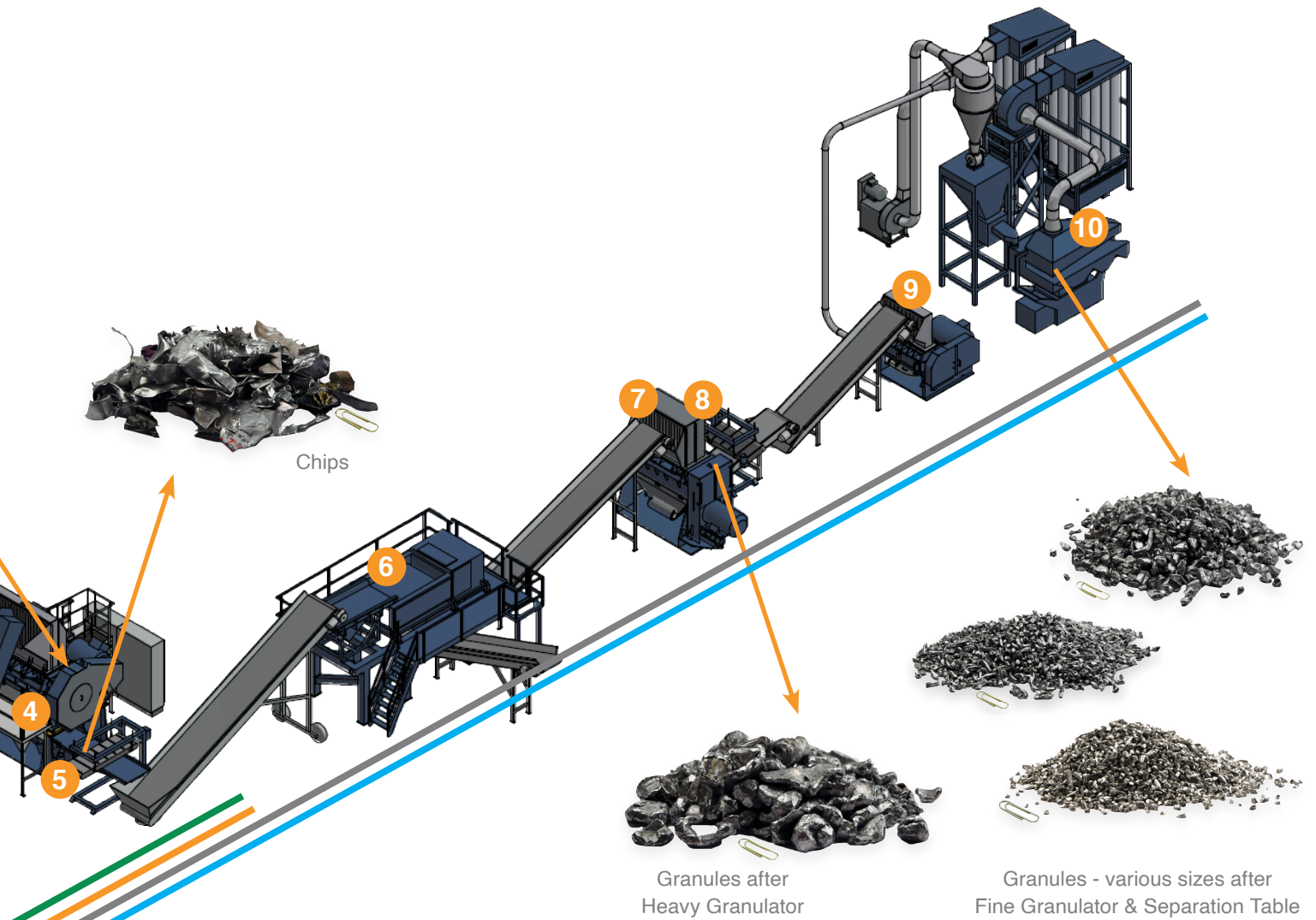
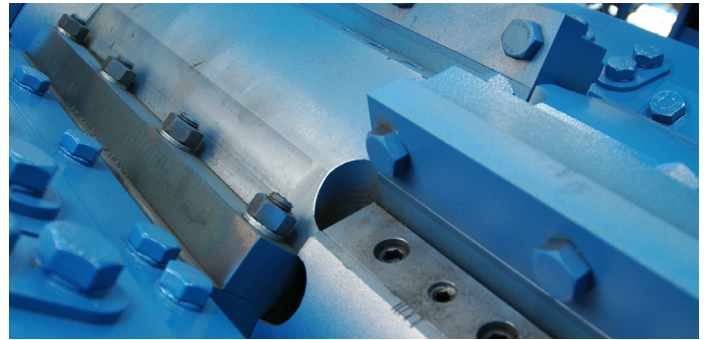
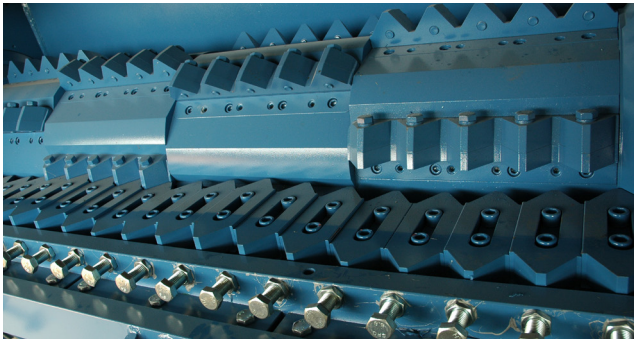
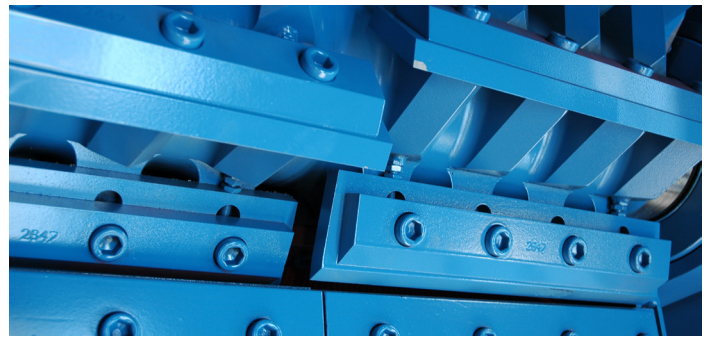

PLANT A  
PLANT B  
PLANT C  
PLANT D  
PLANT E



## Optional modules for specific customer requirements

### Shredder

A powerful, high-speed Ring Shredder for size reduction of aluminium and for breaking down aluminum with a high content of steel/iron.

### Super Chopper II

Used for pre-chopping of high density bales.

### ACSR Shear M16-2

For cutting of ACSR cables.

- Easy to load, Easy to operate, Easy to maintain
- Feeding speed: up to 60 m/minute
- Chopping speed: up to 400 cuts/minute
- Cable diameter: up to 50 mm



ELDAN Ring Shredder

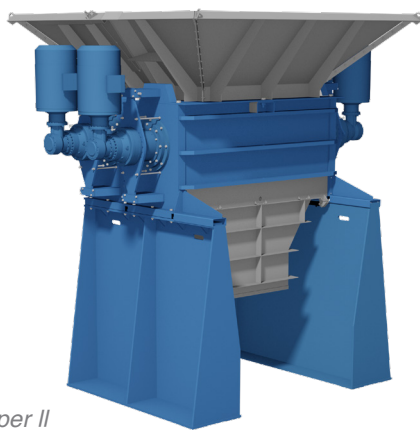

ELDAN Super Chopper II

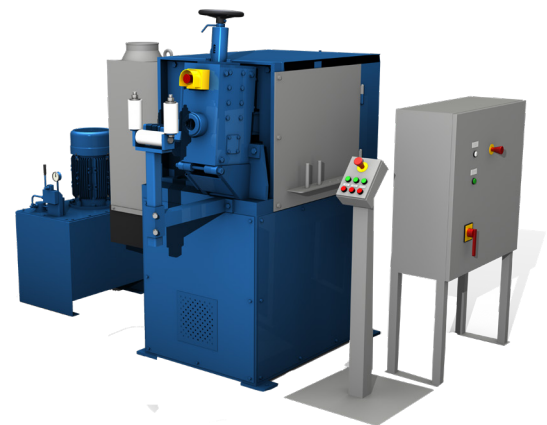

ACSR Shear M16-2

### Ensure reduced downtime!

- The **ELDAN Service Department** offers ad hoc service on existing as well as new equipment through our trained and experienced service engineers and supervisors.
- The flexible service contracts ensure planned, preventive maintenance of your production line.
- The **ELDAN After Sales Department** constantly holds an extensive stock of spare and wear parts.
- Tailored spare parts contracts ensure that parts are available for immediate call off.
- Contact one of our spare and wear part coordinators, and we will supply the best possible solution for you and your company.

### We are your reliable partner!

Service: [service@eldan-recycling.com](mailto:service@eldan-recycling.com)

After Sales: [aftersales@eldan-recycling.com](mailto:aftersales@eldan-recycling.com)

